

**Instruction manual for 20kW
Automatic Set VENTO MULTI with
a cast iron head and container of
up to 1m³**

Note to user.....	3
1. Introduction	4
1.1. Safety instructions	4
1.2. Warranty.....	7
1.3. Fuel.....	8
1.4. Technical description	8
1.5. Equipment.....	12
2. Assembly	12
2.1. General parameters	12
2.2. Boiler room.....	12
2.2.1. Boiler placement	13
2.2.2. Feeder placement.....	13
2.3. Connection to the chimney.....	14
2.4. Boiler connection to the installation.....	14
2.5. Installation safety.....	14
2.5.1. Open system	14
2.5.2. Closed system	15
2.6. Control and electrical connection	17
2.6.1. Safety rules.....	17
2.6.1. Controller specifications	18
2.6.2. Electrical connection.....	19
3. Device operation	24
3.1. Technical description	24
3.2. Burning	24
3.2.1. Loading fuel to the container.....	24
3.2.2. Ignition and setup of burning parameters.....	24
3.2.3. Continuous operation.....	26
3.2.4. Emergency operation	26
3.3. Cleaning and maintenance	27
3.3.1. Cleaning the exchanger	27
3.3.2. Cleaning the head.....	27
3.4. Turning of the device	28
3.4.1. Programmed shutdown	28
3.4.2. Emergency shutdown.....	28
4. Troubleshooting, safe operation conditions	29
4.1. Installation of the fuel container in a non-heated room.....	30
4.3. Troubleshooting	31
4.3.1. Procedure in case of screw shaft jamming.....	32
5. Spare parts	33
5.1. Main spare parts list	33
5.2. List of wearable parts*	33
6. Disposal.....	33

NOTE TO USER

Thank you for purchasing our device and congratulations on a good decision.

Moderator Spółka z o.o. has been manufacturing boilers using proprietary technological solutions developed in late 1970s in Hajnówka by engineer Kazimierz Kubacki. During the last twenty years these boilers have undergone multiple technological changes and upgrades. We have also started production of automatic feeders intended for burning crumbled solid fuels, which combined with a boiler constitute complete Automatic Biomass Burning Sets (AZSB). This instruction manual is based on the latest information of the manufacturer. Due to ongoing development works on the boiler the manual is only applicable for the boiler it is delivered with.

AZSB is intended for heating water up to maximum 80 degrees Celsius in central-heating and hot household water installations as well as in process installations (wood dryers, presses, etc.).

This manual has been designed to assist users in boiler installation, operation, maintenance and servicing. Read the manual carefully before attempting any of the said actions.

1. INTRODUCTION

1.1. SAFETY INSTRUCTIONS

The main condition of safe boiler operation is its correct connection to the central heating installation. The manufacturer has put great effort to make the device as safe as possible. This will only be possible after all connection and operation requirements outlined in this manual are met and complied with. Failure to perform any action, due to involved costs of additional equipment installation will certainly affect the safety or cause the equipment operating costs to rise in the future.

The equipment has been subjected to performance checks and tests, which all have been performed using carefully selected accessories (safety valves, thermal protections) and equipment. In order to guarantee the declared high performance of the equipment, you should only use equipment recommended by the manufacturer.



We would like to hereby advise against using substitute solutions, which have not been checked with that boiler and which do not have required approvals (Technical Supervision Office - UDT) and certificates (declaration of conformity, CE sign). We also advise against any unauthorized changes in the equipment structure and against failing to follow safety instruction described in these instructions.

Failure to follow these recommendations may lead to serious danger and expose the operating personnel to health or life hazard.

In case of doubt, please contact our sales department or an authorized servicing agent.

Safety instructions for basic activities

Maintenance – during maintenance, the device must remain disconnected from the power supply. The power switch (9, fig. 2.3) must be in **0 (zero)** position. During maintenance always check the tightness of connections and condition of cover seals.

Leaks – when filling the tank check if there are any foreign bodies under the cover which could prevent it from being properly closed.

Head – keep in mind that the burner head stays hot long after the device has been switched off. All works on the burner head may only be performed after the temperature drops. The burner head must not be covered and must be kept clean.

Fire safety – leaving open covers or inspection holes or overfilling the container during burner operation may constitute an imminent fire threat. Too much fuel in the container will prevent tight closing of the cover:

- On each visit to the boiler room (at last once per 12 ÷ 24 hours), it is necessary to check whether the fire water tank contains sufficient volume of water,
- Appropriate fire prevention equipment shall be available in the boiler room (acc. to fire brigade recommendations, appropriately sized fire extinguisher, etc.),

- do not store ashes in plastic or cardboard containers. Do not leave ashes in premises unsupervised (even if in non-combustible containers),

Protective equipment – chips, sawdust and ashes may contain carbon monoxide, dusts and allergens. When working with this fuels, use appropriate means of personal protection. Note that ashes may contain concealed glowing coal particles. When working with ashes, use suitable gloves.

Clothing – When working in the boiler room, due to personal safety considerations, use infusible and non-combustible clothing.

Safety and Warning Signs

Please pay attention to the warning and safety signs, minding their meaning and placement on the equipment. They are designed to avoid accidents.



Pay special attention in the boiler room keeping in mind that various parts of the boiler and systems may be hot. Keep a safe distance.



The device may periodically switch on without warning. Do not perform any works on a connected and switched on device.



This boiler may only be operated by people familiar with the content of this instruction manual.



The transport worm may start operating without warning. Switch off power supply before lifting the cover.



Do not stand on the housing.



The container may contain carbon oxygen and dust. Vent the container before commencing with loading or prior to its opening.



This sign placed on pages of these instructions indicates a warning. Please read corresponding section with utmost care so as to avoid many dangerous situations in the future.



This symbol marks useful information and tips.



Keep in mind that many parts and surfaces in the boiler room may have high temperatures. Pay special attention as doors may have higher temperature than other parts of the boiler. This also applies to smoke conduit and supply and return pipes. Always stay alert in the boiler room.



Please note that ashes and fuel may cause allergic reactions. Also, during operation in the charging container, carbon monoxide may accumulate. We recommend wearing protective gloves and appropriate dust masks.



Remember to keep boiler room tidy. Leaving fuel piles on the floor may lead to a fire.



The container cover must be opened carefully due to escaping combustion gases and flames from the glowing fuel, forming in result of sudden inflow of larger volume of oxygen from outside.

1.2. WARRANTY

The manufacturer grants 24-month warranty for the device, which includes workmanship and material faults.

The warranty does not cover damage resulting incorrect use or normal wear and tear. The warranty does not include refund of installation costs, refund of travel costs, damages in transport, damages caused by changes or repairs performed without manufacturer's authorization.

All complaints shall be always filed to the boiler vendor. When filing a complaint, please provide the following:

- • fault description
- • proof of device purchase
- • boiler output, head rated power
- • boiler and Smok device serial numbers

Declaration of Conformity

We,
Moderator Spółka z o.o.
11 Listopada 16a
17-200 Hajnówka
tel. (085) 682-75-20

hereby declare, on our own and sole responsibility that the product: Smok Automatic Biomass Burning Set, with serial number starting from 250, to which this declaration applies, meets the following requirements and standards, where applicable:

Directives	Norms
98/37/WE	EN-PN ISO 12100
97/23/WE	EN-PN 303-5

Hajnówka, 15.11.2012

PREZES ZARZADU
mgr Mariusz Kubacki

1.3. FUEL

Use only recommended fuels.



AZSB is designed to burn crumbled fuels from renewable sources and wood and vegetable products, such as (chips, sawdust, bark, bricks, pellet with a bulk density of 450kg/m^3) with humidity content of up to 25%. Technical parameters of the device are specified for fuels with humidity content of 12,39% and calorific value of $Q = 15779\text{ kJ/kg}$.



Avoid burning too fine fuels (such as saw dust), in which dust content exceeds 5%, as it may lead to an explosive combustion of dust. You should not compact the fuel as it may lead to its suspension.



In case of fuels with a bulk density below $100\text{ kg/cubic meter}$ the device may not reach its nominal power. **Such fuels include chips from a panel planer.**

Table 1.1. Approximate data of various fuels

Fuel type	burning time of 1	1 cm weight	humidity
	c.m.* (h.)	(kg)	(%)
Briquette	76	400	10
Chips	42	250	25
Sawdust	24	145	25
Pellets	150	700	6

* c.m. - cubic meter

1.4. TECHNICAL DESCRIPTION

The AZSB (fig. 1.1.) consists of a Moderator-type boiler and fuel feeding system with a container, manufactured by Moderator Sp. z o.o. in Hajnówka.

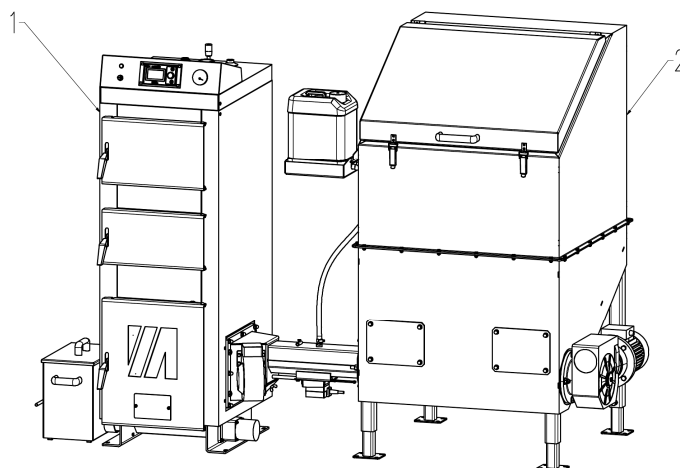

Fig. 1.1. Automatic biomass burning set AZSB20GZ 0.6m^3

1 - boiler, 2 - fuel feeding system

This manual only applies to the following devices:

- AZSB20GZ 0.6m³
- AZSB20GZ 1m³

Heat exchanger

The heat exchanger (*Fig. 1.2*) is a low-temperature water boiler. The exchanging surface of the boiler is made of quality boiler sheet steel (P265GH steel). The ash removal system is a part of the optional equipment. However, the exchanger by default is able to be fitted with the system, and it can be installed also during use.

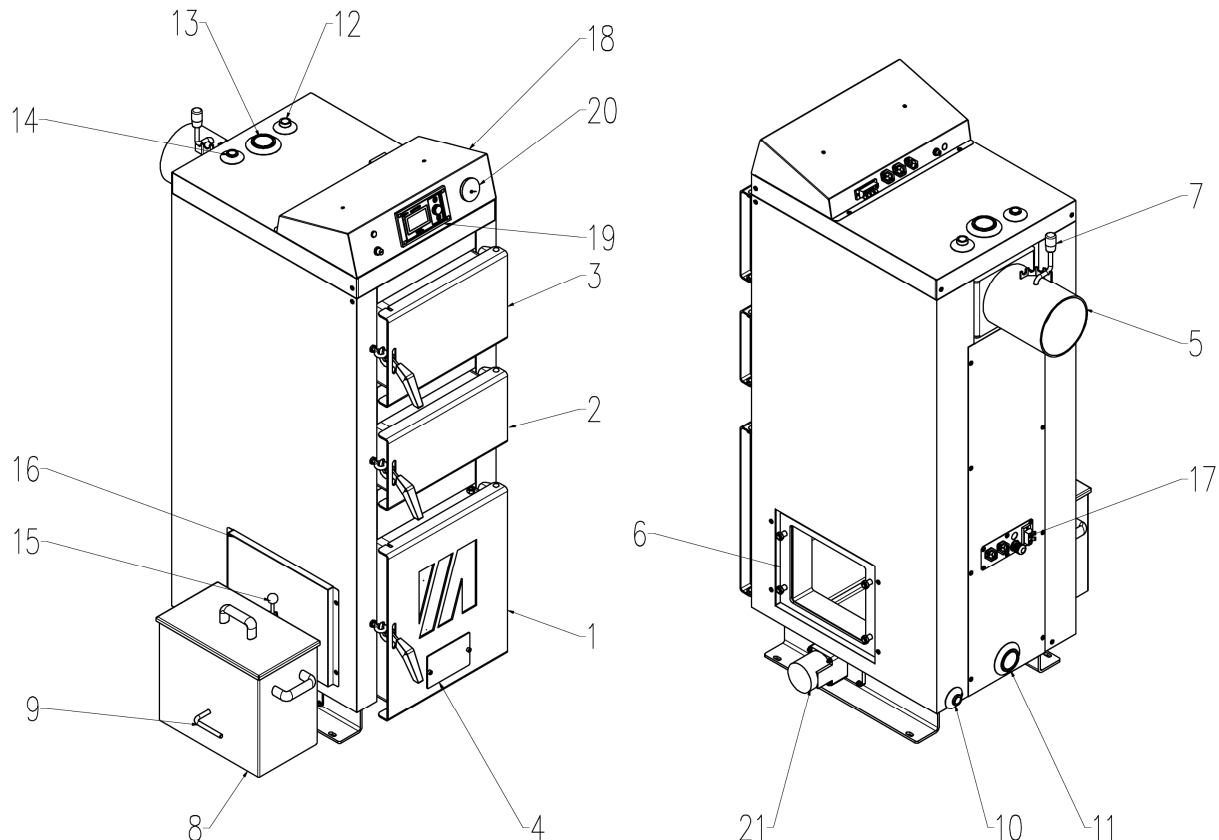

Fig. 1.2. Moderator 20kW exchanger - description of main elements.

1 - ignition and ash removal door, 2 - combustion chamber cleaning (load) door, 3 - exchanger cleaning door, 4 - air throttle opening, 5 - flue, 6 - head fitting frame, 7 - flue gas throttle, 8 - ash container, 9 - ash container cover, 10 - drain valve connection, G1/2 male, 11 - return connection, G1½ male, 12 - safety valve connection G3/4 female, 13 - supply connection, G½ male, 14 - thermal safety connection, G1½ male, 15 - ash container blockade, 16 - head connection opening cover, 17 - rear connection panel, 18 - controller casing, 19 - controller panel, 20 - thermo manometer, 21 - ash removal system gear motor.

On special occasions the exchanger can be used to burn solid fuels in a traditional fashion by loading the combustion chamber manually. Such combustion should only be treated as an alternative for emergency situations (such as power outages, feeder malfunctions) and normal, automatic operation should be reinstated as quickly as possible. **In emergency mode, fuel is loaded manually via the loading door.**

Before igniting the boiler with a manual load, you must install the cast iron grate and air throttle provided with the device. To install the grate you must put it on the supports

inside the combustion chamber above the head. The air throttle should be installed in the connection on the ash tray door (4, Fig. 1.2).

Fuel feeding system

The primary elements of the fuel feeding system include:

- cast iron head
- Fuel container
- gear motor
- screw shaft
- extinguishing system

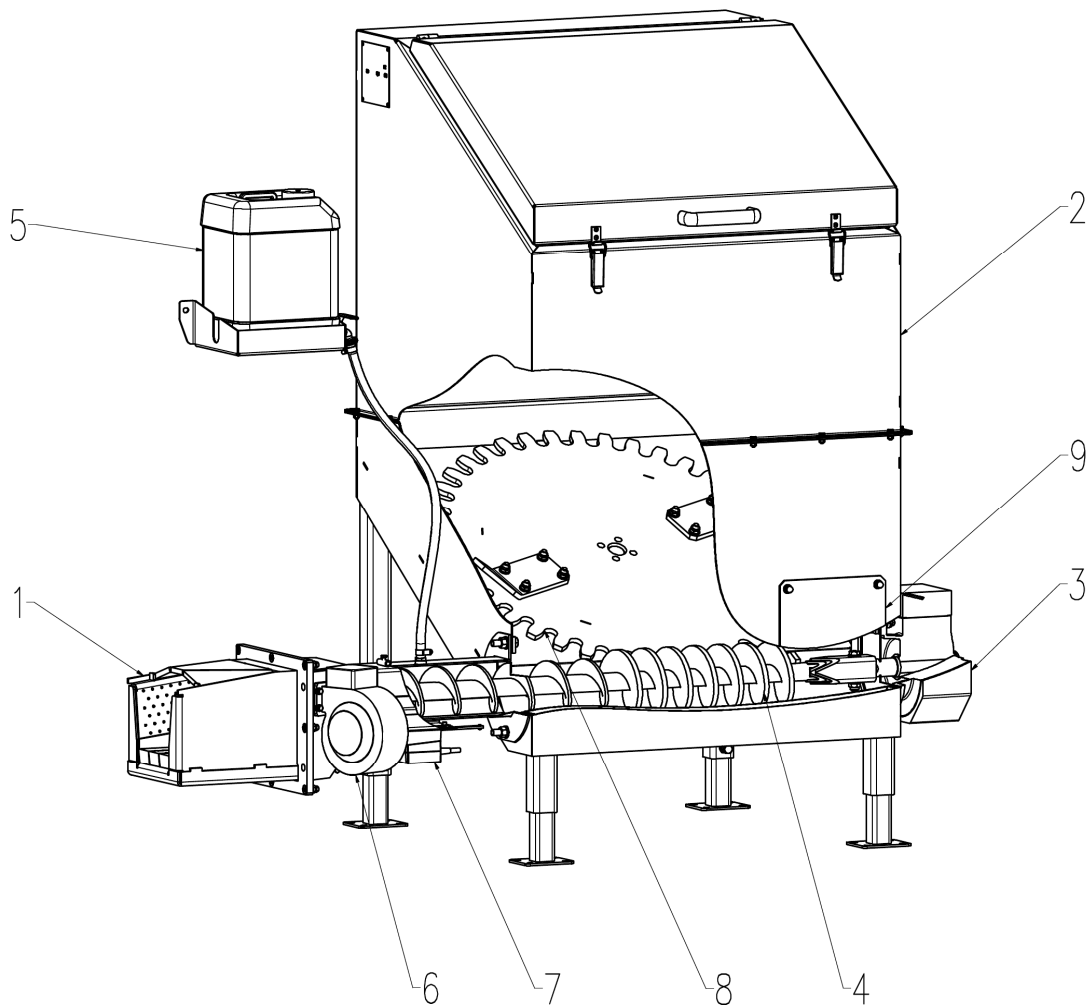

Fig. 1.3. Fuel feeding system with a 0.6 m³ container and a 20 kW cast iron head.

1 – cast iron head 20 kW, 2 – Fuel container, 3 – gear motor - shaft, 4 – screw shaft, 5 – extinguishing system, 6 – fan, 7 – grate drive, 8 – agitator, 9 – inspection hole.

Cast iron head

The cast iron head (*Fig. 1.4*) is located inside the combustion chamber of the boiler. The cast iron grate works on the following principles: the fuel from the container (2, *Fig. 1.3*) is transported to the furnace of the head via the screw shaft, where it is burned at high

temperatures thanks to the air supplied by the fan. The furnace of the head is equipped with a segmented grate whose elements are in a reciprocating motion towards each other. The movable grate is designed to remove debris from the grate. The movements of the grate are powered by an electrical actuator (5, Fig. 1.4).

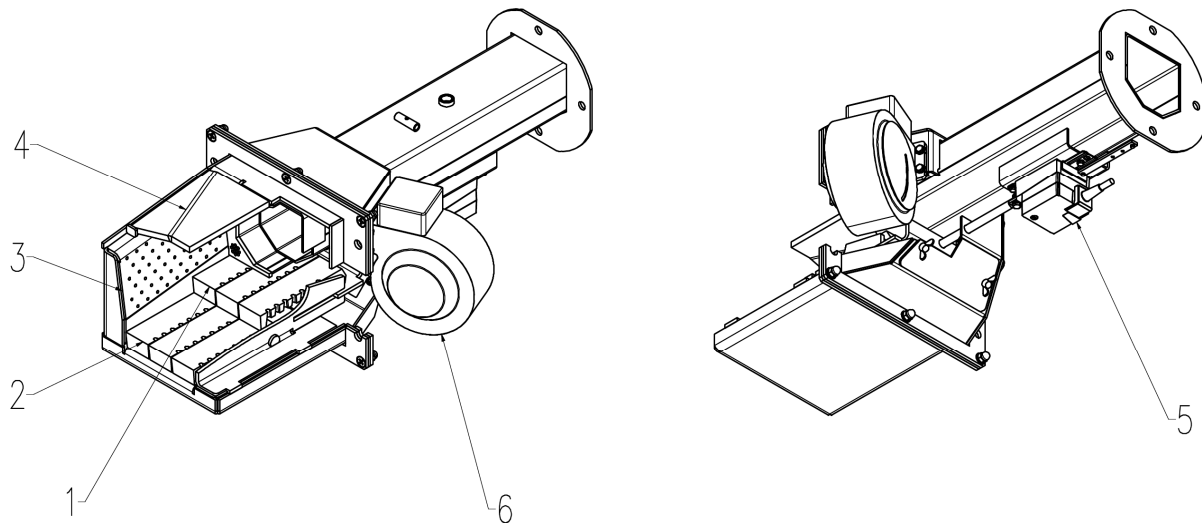

Fig. 1.4. 20kW Cast iron head

1 - Movable grate, 2 - fixed grate, 3, grate furnace, 4 - head cover, 5 - grate drive actuator, 6 - fan.

Fuel container

The AZSB20 sets can come with a 0.6m³ or 1 m³ container.

The containers are made from steel sheets and have an agitating disk for loosening the fuel with stiff or spring reels. The screw shaft rotates the agitator. The design of the container allows to turn the body of the container (by 90°) against its base, allowing the loading opening to be directed the way the user wants it to.

Extinguishing system

The extinguishing system prevents fire from moving from the furnace to the fuel container. Its elements include a water-filled tank, a valve, and a flexible hose ending with a wax sealed connection. The wax-filled connection is connected to the feeder canal at a specific position from the furnace. When the flame is moving along the feeding canal, it heats up its cover along with the wax sealed connection. When the connection reaches a temperature of approx. 50°C, the wax melts and the water from the tank floods the feeder and extinguishes the fire. After the extinguishing system takes action you must:

- disconnect the connection from the feeder and elastic hose
- fill the connection with bee's wax (pour hot wax into it)
- connect the connection with the feeder and elastic hose
- refill the water tank

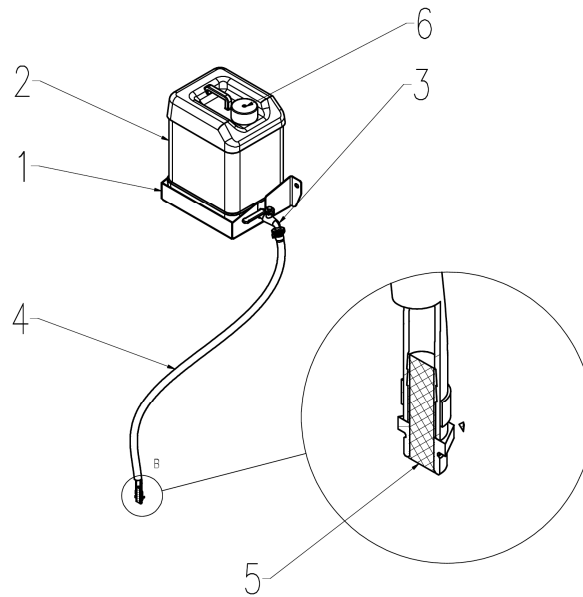

Fig. 1.5. Extinguishing system

1 - Water tank holder, 2 - water tank, 3 - valve, 4 - elastic hose, 5 - bee's wax
6 - air vent

1.5. EQUIPMENT

The boiler is supplied assembled. Its basic equipment includes:

- Thermo manometer,
- cleaning kit,
- cast iron grate,
- controller,

The fuel feeding system is supplied partly assembled. Some of the feeder elements, after testing in the factory, are disassembled and packed inside the container or on a transportation palette in order to facilitate transport and bringing the device into the boiler room.

2. ASSEMBLY

2.1. GENERAL PARAMETERS

- Maximum supply temperature - 85°C,
- Recommended minimum return temperature - 55°C,
- Operating pressure - 1.5 bar,
- Thermal efficiency - 85.9%,
- Combustion gases minimum temperature - 180°C,

2.2. BOILER ROOM

The boiler room should meet the requirements of the PN-87/B-02411 standard. Here are some of the most important of requirements:

- waterproof flooring,
- steel or wooden doors lined with sheet metal, opening outwards,
- 21x21 cm air supply hole in the bottom part of the boiler room,
- at least a 14x14 cm exhaust hole in the upper part of the boiler room,

Equipment:

- tap,
- sewage well,
- sink,



Do not use forced ventilation in the boiler room.

2.2.1. BOILER PLACEMENT

The installation of the heat exchanger (boiler) should be performed by a qualified and experienced installer (we recommend contacting one of our representatives whose installers have been trained by Moderator Sp. z o.o.). **Faulty installation can cause premature war of the boiler, may result in fire or lead to an explosion.**

When placing the boiler, consider such a position that does not prevent the walls from easy fuel load, sweeping, or access to cleaning holes.

2.2.2. FEEDER PLACEMENT

Preparation:

1. Remove all loose parts from the container, remove the grate from the boiler and tightly close all air inlets to the device.
2. Make sure to leave enough room in front of the burner head so that ashes can fall freely into the ash tray.
3. Find a suitable position for the extinguishing tank and prepare enough hose (the hose is provided with the device). To ensure safe operation, the water tank should be mounted to the wall of the boiler room, not the cover of the fuel container. The bottom of the container must be at least 50 cm above the top of the feeding canal. Ensure that the water hose is not bent or twisted.
4. Make sure that you have the appropriate tools to begin installation (set of wrenches).

Installation (parts according to fig. 1.3):

1. Screw the head (1) to the fuel container.

2. Insert the screw shaft (4) into the container and feeding canal and fasten it to the shaft of the hear motor using an M12x70 screw fastened to the end of the screw shaft.
3. Screw the fan (6) to the head.
4. Regulate the legs of the container to set the proper height of the head.
5. Insert and screw the head to the connecting frame of the boiler; the boiler must be levelled.
6. Install the extinguishing tank (5); connect the elastic hose with the wax-filled connection and secure it with a zip tie, release the valve and make sure that the cap of the tank has an air vent.
7. Connect the electrical installation and sensors (see section 2.6. Installation of the control system and electrical connections).

2.3. CONNECTION TO THE CHIMNEY

The flue is best connected directly into the chimney, and the connection should be sealed. [The chimney should comply with standing norms.](#)

Table 2.1. Chimney parameters, depending from device power.

Boiler power kW	Square chimney cm x cm	Round chimney cm	Min. chimney draught Pa
20	16 x 16	16	27

2.4. BOILER CONNECTION TO THE INSTALLATION

The 20kW Moderator exchanger is intended to work with a closed or open system.

The Boiler will operate correctly if the temperature inside the combustion chamber will be sufficiently high, which means that the supply water should have a temperature between 70-80°C, and that the returning water should not be less than 55°C. [Such operating parameters will protect the boiler against low-temperature material corrosion. In order to ensure correct operation of the boiler, the manufacturer recommends installation of a mixing valve.](#)

20 kW boilers have threaded G1½ pipe stubs. [The connection of the stubs with the installation should be performed using appropriate couplings. Stub descriptions as in fig. 1.2](#)

The boiler and the system should be filled with water by using the G½ drain valve. [This should be performed slowly to ensure that all air is released from the installation. The water in the boilers should be free from grit and organic pollutants and meet the requirements of the PN-85/C-04601 norm. Loss-less installation can be filled with crude water, unless its hardness does not exceed 10%. If it does, the water should be treated.](#)

2.5. INSTALLATION SAFETY

2.5.1. OPEN SYSTEM

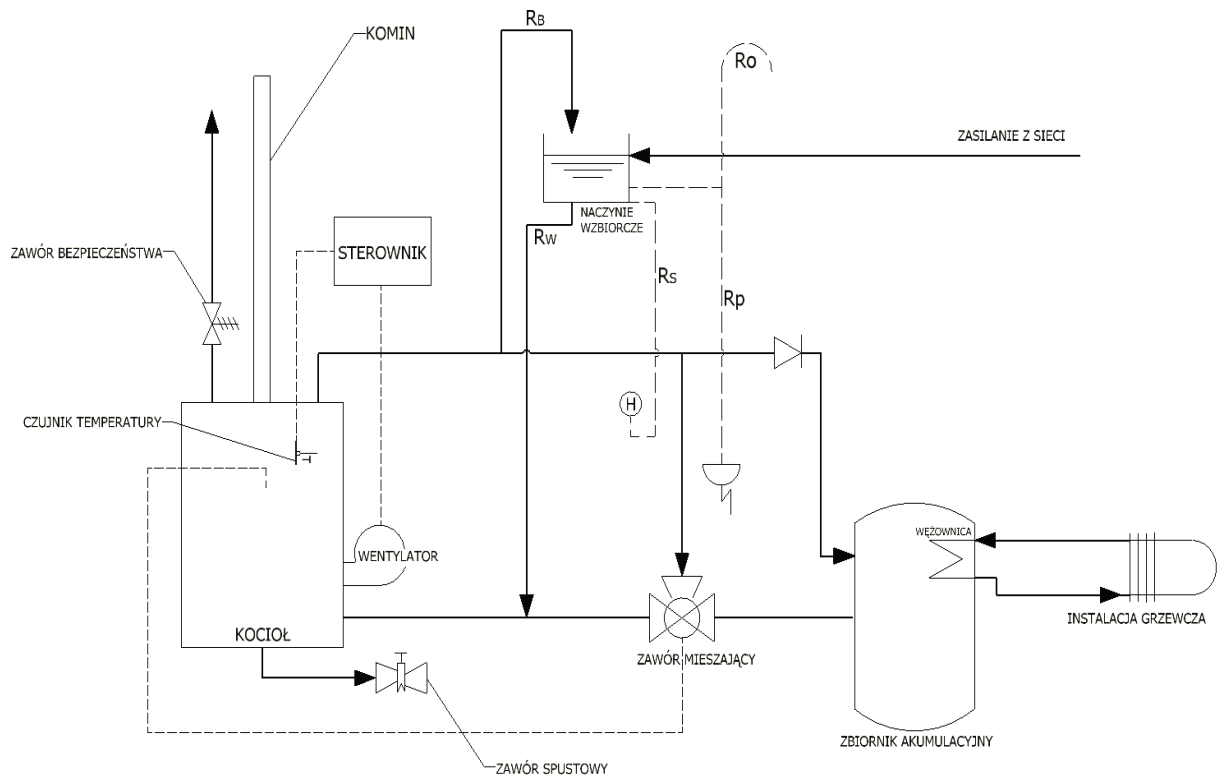

Fig. 2.1. Diagram of installation protection for boilers operated in open central-heating installations

KOMIN – CHIMNEY	ZAWÓR BEZPIECZEŃSTWA - SAFETY VALVE
CZUJNIK TEMPERATURY – TEMPERATURE SENSOR	KOCIOŁ – BOILER
STEROWNIK – CONTROLLER	WENTYLATOR – FAN
ZAWÓR SPUSTOWY – DRAINAGE VALVE	NACZYNIĘ WZBIORCZE – PRESSURE VESSEL
ZAWÓR MIESZAJĄCY – MIXING VALVE	ZBIORNIK AKUMULACYJNY – HEAT ACCUMULATION TANK
WEŻOWNICA - COIL	INSTALACJA GRZEWCZA – HEATING INSTALLATION
ZASILANIE Z SIECI - WATER PIPE SUPPLY	

Moderator boilers operating in open central heating systems must be connected according to requirements of the PN-91/B-02413 standard, so that excess heat in the form of steam shall be removed through an open connection (Rb overflow pipe) to the atmosphere.



No fittings permitting complete or partial closure of flow may be installed on Rb, Rw and Ro pipes. The protective equipment and pipes should be protected against freezing.

2.5.2. CLOSED SYSTEM

Moderator boilers working in closed systems should be connected to the installation according to the requirements of PN-B-02414:1999 and the provisions of the minister of infrastructure from 12.03.2009 on the technical conditions of buildings and their placement. Paragraph 133 of this provision reads: "It is forbidden to use a solid fuel boiler in closed water heating systems with an expansion vessel, except boilers with a nominal power under 300 kW equipped with a heat dissipating device."



The manufacturer's recommended SYR 5067 thermal protection is only and exclusively effective if the pressure in water pipe network can be guaranteed at the min. level of 2.3 bar and if safety valve is installed. The maximum power of devices supported by the SYR 5067 valve is 100kW, therefore more powerful devices should be installed in an open system.

Thermal protection should be connected only to a water source which will ensure water supply even during power outages (for example, water networks).

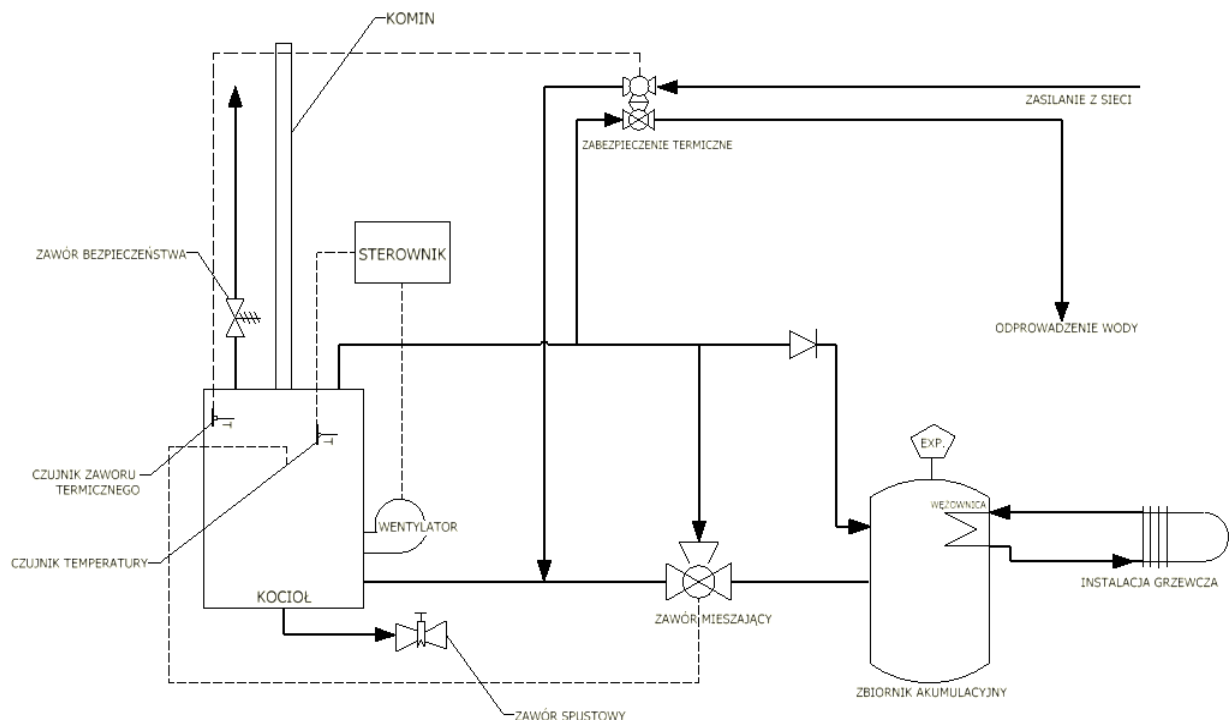

Fig. 2.2. Diagram of installation protection for boilers operated in closed central-heating installations

KOMIN – CHIMNEY	ZAWÓR BEZPIECZEŃSTWA - SAFETY VALVE
CZUJNIK ZAWORU TERMICZNEGO – THERMAL PROTECTION VALVE SENSOR	KOCIOŁ - BOILER
CZUJNIK TEMPERATURY - TEMPERATURE SENSOR	WENTYLATOR – FAN
STEROWNIK – CONTROLLER	ZABEZPIECZENIE TERMICZNE – THERMAL PROTECTION
ZAWÓR SPUSTOWY – DRAINAGE VALVE	ZBIORNIK AKUMULACYJNY – HEAT ACCUMULATION TANK
ZAWÓR MIESZAJĄCY– MIXING VALVE	INSTALACJA GRZEWCZA – HEATING INSTALLATION
WĘŻOWNICA - COIL	ODPROWADZENIE WODY – WATER DRAINAGE
ZASILANIE Z SIECI - WATER PIPE SUPPLY	

2.6. CONTROL AND ELECTRICAL CONNECTION

2.6.1. SAFETY GUIDELINES

1. Before connecting the device, it is necessary to read boiler and controller operating instructions.
2. Before commencing with installation, repairs or maintenance or when performing any connecting works, it is absolutely necessary to disconnect the power supply and to make sure that there is no live supply on any of terminals or cabling.
3. The boiler room should be equipped with 230V/50Hz electric power system, compliant with applicable regulations
4. The electric system should be terminated with power supply receptacle with a protective terminal. **Use of power receptacles without connected protective terminal may cause electric shock hazard!!!**
5. The cabinet with the electrical accessories are installed may only be opened by a qualified electric engineer knowledgeable with the device operation.
6. Location of the power socket used for the controller connection shall be chosen in such a way, so that the power plug is readily accessible for quick disconnection in case of an emergency.
7. Electric cables shall be well fixed on their whole length. Wires shall be guided away from heating parts of the boiler and in particular away from hot elements of the head, flue conduit and chimney.
8. The controller may not be exposed to water and to conditions causing water condensation, e.g.: sudden changes of ambient temperature.
9. The controller must not be operated if its cover is broken or damaged.
10. The controller shall be installed in a place inaccessible for children.
11. During thunderstorms, the controller should be plugged off from the power supply network.

2.6.1. CONTROLLER SPECIFICATIONS

The automatic control is based on the ecoMAX 800R microchip regulator by PLUM. The controller's function is to maintain a set temperature in the boiler. Based on the temperature in the boiler, the controller adjusts the amount of fuel and air supplied to the furnace of the head. The temperature of the feeder is also monitored (a sensor installed in the feeding canal), in order to prevent the flame from returning to the fuel container.

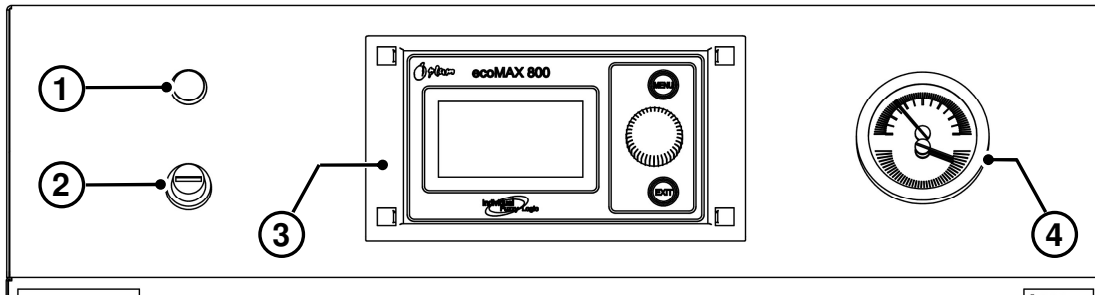

Fig. 2.3. Controller - front view

1 - STB temperature limiter signal lamp, 2 - STB temperature limiter, 3 - regulator panel, 4 - thermo manometer

Figure 2.3 outlines the elements of the control system. *The Regulator Panel (3)* is used to set parameters.



Detailed information on particular parameters, button functions, parameters settings, current capacity, etc., are provided in the regulator manual added to the boiler.

Next to it there is the *thermo manometer (4)* which is used to read the temperature and pressure in the central heating system, also during a power outage. *The temperature limiter (2)* prevents the water in the boiler from reaching excessive temperatures. When the limiter is switched on (upon the boiler temperature exceeding 95°C) the operation of the feeder and fan is stopped. When the limiter is on, the lamp (1) lights up. To restart the boiler you must unscrew the black cap of the temperature limiter and press the button underneath it. Use a match or other small object to push the button. The button will make a characteristic "click".



Press the button when the temperature on the boiler falls below 50°C.

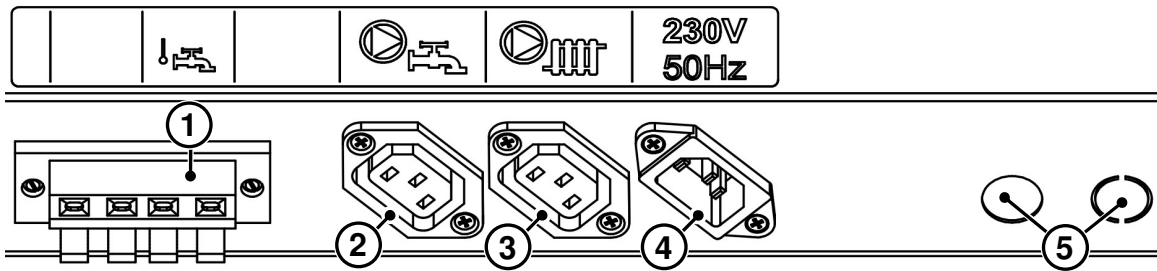

Fig. 2.4. Controller - rear view

1 - domestic hot water temperature sensor, 2 - domestic hot water pump socket, 3- central heating pump socket, 4 - power supply socket (230V AC), 5 - cable grommets

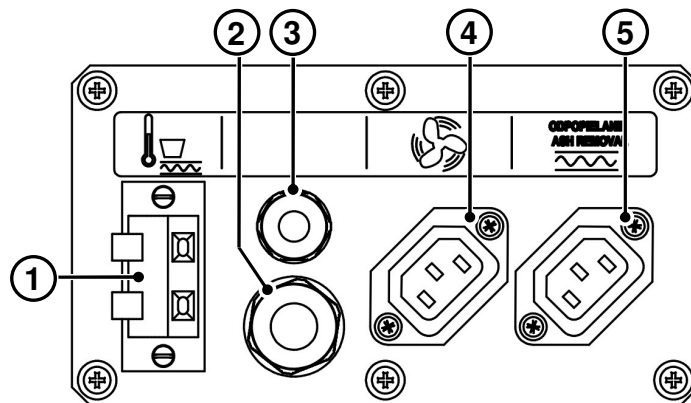

Fig. 2.5. Socket panel - rear of the boiler

1 - Feeder temperature sensor, 2 - engine connection cable, 3 - movable grate actuator cable, 4 0 fan socket, 5 - ash removal socket

Figures 2.4 and 2.5 illustrate the connection sockets for the various elements of the AZSB set.

The boiler regulator can additionally be equipped with a mixing valve drive, domestic water pump, central heating pump, mixing valve temperature sensor, external temperature sensor, return water temperature sensor, room thermostat. **The equipment listed above is not included with the boiler by default.**



The only room thermostat that will work with the regulator is the ecoSTED dedicated room panel by PLUM. It is impossible to connect a typical thermostat with a no/nc contact.

2.6.2. ELECTRICAL CONNECTION

The boiler comes with a set of elements used to connect the power supply and the corresponding equipment with the regulator, as seen on fig. 2.6.

Power supply

The power cable (1, Fig. 2.6) is supposed to be connected to the socket at the back of the controller.

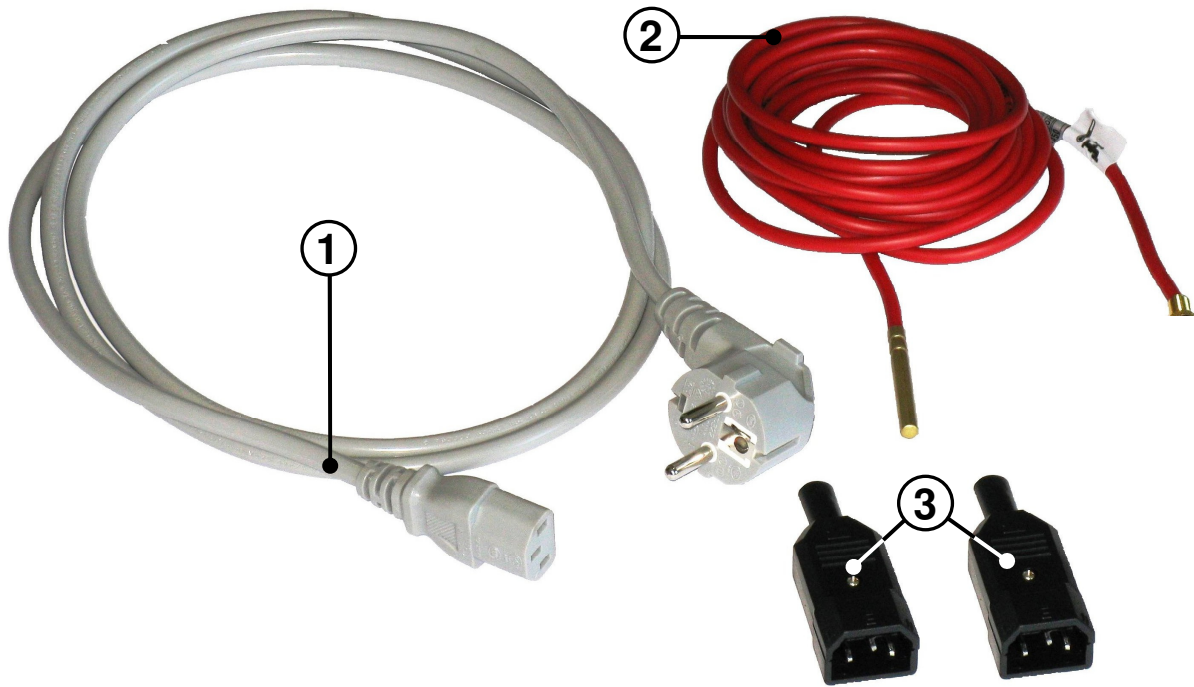

Fig. 2.6. Additional accessories.

1 - power cable, 2 - domestic hot water temperature sensor, 3 - computer plugs used terminate the cables of the central heating and domestic hot water pumps.

FEEDER MOTOR

The motor is connected with a cable which leaves the back of the boiler and ends with cable plugs. The connection should be made in accordance to the schematic below (*Fig. 2.7*).

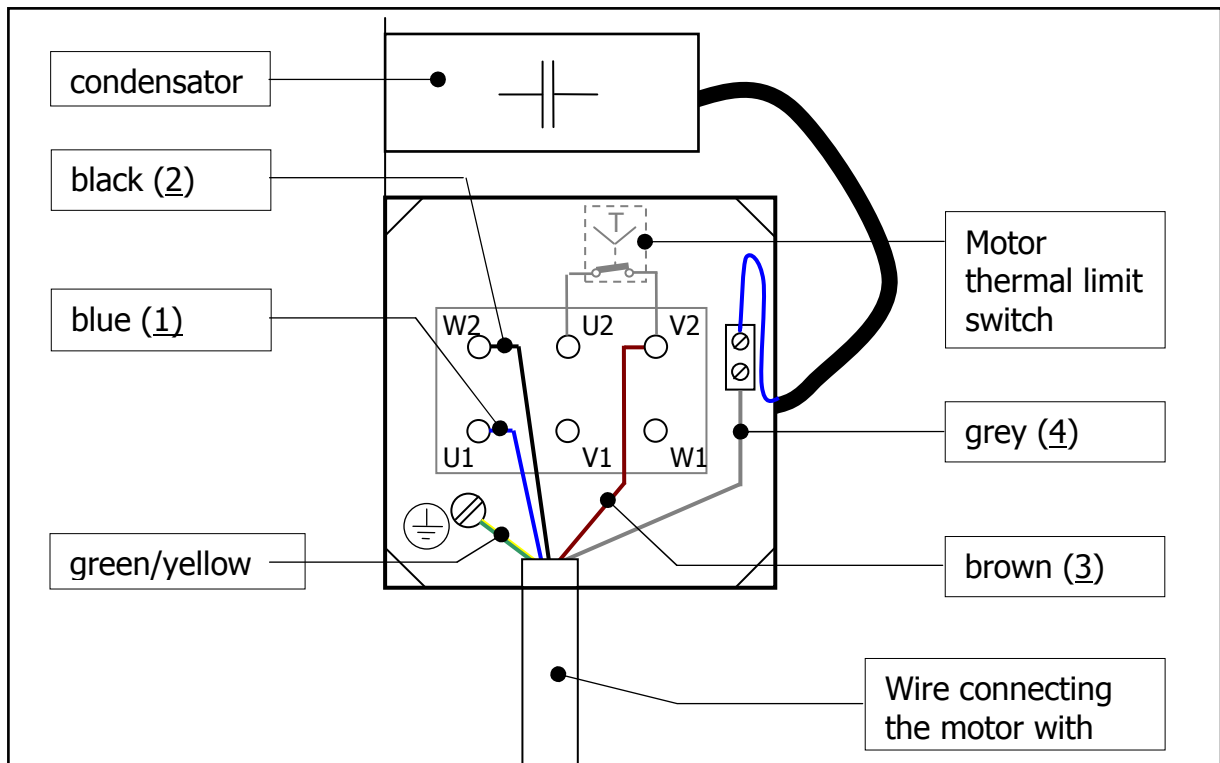

Fig. 2.7. Inside of the connecting cabinet of the motor.

After connecting the motor you must check the direction the screw revolves in. To do this, set the regulator panel to IGNITION mode (see the manual for the ecoMAX800 regulator) and turn on the feeder. The screw should turn in such a direction that pushes the fuel into the head. If it does not, switch the black (2) and grey (4) wires causing the revolutions of the screw to reverse.

Movable grate drive

The connecting cable of the movable grate drive leads from the rear of the boiler. The cable ends with a plug and is used to connect the drive according to the following schematic.

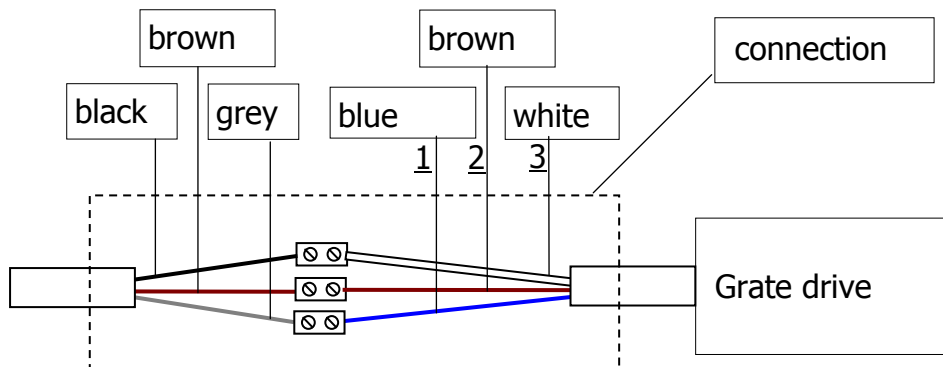

Fig. 2.8. Movable grate drive connection schematic

FAN

The power cable is supposed to be connected to the socket (4, Fig. 2.5) at the back of the boiler.

CENTRAL HEATING PUMP

The central heating pump is connected to socket 3 (fig. 2.4).

HOT WATER PUMP

The hot water pump is connected to socket 2 (fig. 2.4). The hot water sensor is connected to connections 1 (fig. 2.4). The shell of the sensor should be placed inside the hot water tank, in the sensor opening.



To lengthen the wire, use a 2x0.5mm² wire.

The sensor should be mounted dry, do not flood it with oil or any other liquid.

ASH REMOVAL

The ash removal engine is connected to socket 5 (fig. 2.5).

MIXING VALVE DRIVE

The mixing valve drive should be connected directly to the clamps of the output module's connection frame. The module is inside the metal cover of the controller. Lead the wire through the grommet on the back of the controller (5, Fig. 2.4).



The controller cooperates only with those drives of mixing valves which have a limit switch. **Do not use other drives. You can use drives which have a full spin cycle ranging from 30 to 255 s.**

Specific information on connecting and configuring the regulator to work with a driven mixing valve are contained in the regulator manual.

FUEL FEEDER TEMPERATURE SENSOR

The measuring sensor (C, Fig. 2.9) should be installed into the socket (T) and fastened with a screw (S). **In order not to damage the metal casing of the sensor, tighten the screw with your hands. Connect the sensor to the terminal at the back of the boiler (1, Fig. 2.5).**

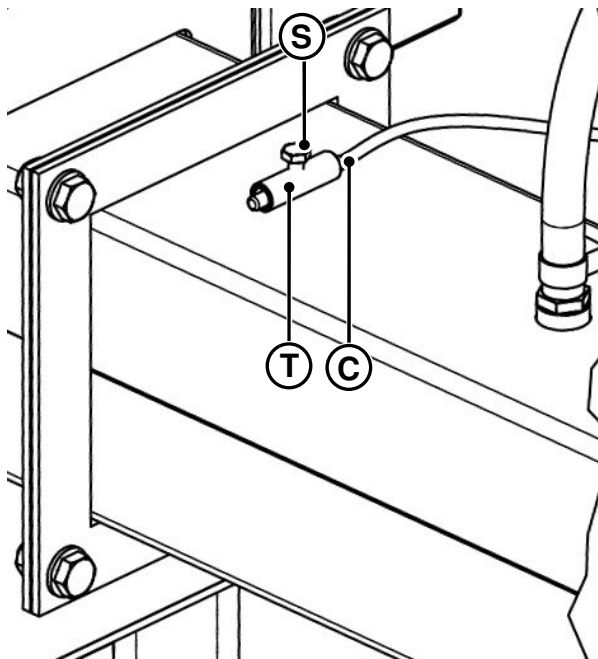

Fig. 2.9. FUEL FEEDER TEMPERATURE SENSOR INSTALLATION

S- Fastening screw, T - socket, C - Feeder temperature sensor.

PRIMARY MIXING VALVE TEMPERATURE SENSOR

When using a motor driven mixing valve, connect the sensor of the mixing valve to the clamps of the output module's connection frame.

In the case of complex central heating installations with more than one motor driven mixing valve, it is possible to expand the controller with an additional MX.01 module to support two mixing systems.

WEATHER SENSOR

The weather sensor should be mounted on the coldest wall of the building, usually the one facing north in a roof-covered spot. The sensor should not be exposed to direct sunlight or rain. **Mount the sensor at approx. 2 m above ground level, away from any windows, chimneys, or any other heat sources that could interfere with the temperature reading. Connect the sensor to the clamps of the controller's output module.**



The mixing valve temperature sensor, weather sensor, mixing valve motor drive, ash removal system are not included in the boiler's standard equipment.



You must remember that the total current of the devices connected to the regulator (fan, central heating pump, hot water pump, mixing valve motor drive) cannot exceed 6 A.

3. DEVICE OPERATION

3.1. TECHNICAL DESCRIPTION

The operation of the AZSB set is based on creating exhaust gases by combusting fuel on the furnace of the head and exchanging heat between the gases and the heating medium. The fuel on the furnace of the head is fed by the screw shaft from the fuel container. The combustion process is controlled by the controller, whose main function is the maintenance of the set temperature of the heating medium. Depending on current temperature of the heating medium, the device selects one of two work modes: <OPERATION> if the temperature is below the set temperature, and <CONTROL> if the set temperature is reached.

3.2. BURNING



Do not load fuel directly to the furnace chamber of the boiler as this may damage the head. When burning fuels with a high dust content (mainly sawdust) under no circumstance open the boiler's doors during operation. Sudden access of air may cause an explosion. Do not allow the head to work while partially covered with ash. Poor cooling of the very quickly lead to the destruction of the steel cover or cracks in the plates of the furnace.

3.2.1. LOADING FUEL TO THE CONTAINER

Be careful when loading fuel to the container and avoid excessive dusting and compaction of fuel. **Compacting fuel can lead it to suspend in the container.**



DO NOT compress fuel in the container.

3.2.2. IGNITION AND SETUP OF BURNING PARAMETERS

Before igniting, set the parameters of the container and fan operation according to table 2.1 and set the temperature of the boiler.

After completing the above functions, set the controller into <IGNITION> mode. Turn on the feeder and supply fuel until it appears on the grate. Next, using some kindling fuel (paper, cardboard, grill lighting fluid) ignite the fuel on the grate and turn on the fan. **As the fuel is burning, supply small amounts of fuel for approximately 10 minutes in order to heat the head. After heating the head, press the EXIT button so that the device enters <OPERATION> mode. Next, correct the feeding, pause, and fan power settings in <OPERATION> mode (if necessary). These parameters should be adjusted depending on the amount of fuel in the head. Do not allow partially burned fuel to be moved to the ash drawer (too much fuel and/or too little air). Do not allow too little fuel to be burned in the front part of the head's furnace (too little fuel and/or too much air).**

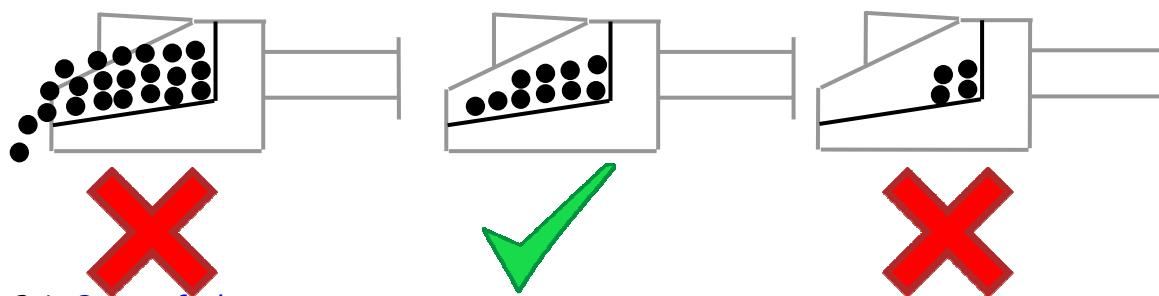

Fig. 3.1. *Correct fuel amount*

Figure 3.1 shows various amounts of fuel in the head's furnace. The middle illustration shows the optimal amount.

Signs of well-adjusted combustion parameters include:

- A bright yellow flame in and outside the fireplace, without smoke
- In the case of a cast iron grate, the sides of the fireplace and the cover are lined with a bright ashen deposit
- The walls of the first boiler chamber or exchanger (combustion chamber) are covered with a bright ashen deposit
- The flue gases leaving the chimney are not smoky (dark smoke), and should show rippling warm air

Table 3.1. *AZSB20 initial combustion parameters*

Type of power and head [kW]	Type of fuel (type of actually used fuel, do not confuse with type of fuel set in control cabinet)	MODE				
		OPERATION			CONTROL	
		Feed time OPERATION	Feed interval OPERATION	Fan power	Feed time CONTROL	Feed interval CONTROL
		Feed time OPERAT	Feed interval OPERAT	Fan power	Feed time CONTR	Feed interval CONTR
		[sec.]	[sec.]	[%]	[sec.]	[min.]
GZ 20	chips	2	45	65	2	5
	bricquette	2	40	65	2	5
	sawdust 1	3	25	55	2	3
	sawdust 2	3	18	45	2	3
GZ 30	Chips	2	45	65	2	5

In <CONTROL> mode, the feed and interval time should be adjusted so that:

- The temperature of the boiler does not increase; rising temperature may lead to the activation of the overheating protection (STB) and automatic shutdown of the device.
- partially burned fuel does not fall into the ash drawer

¹ sawdust fragmentation like from a circular saw with a relative humidity below 25%

² sawdust fragmentation like from a planer with a relative humidity below 25%

- the ambers from the fireplace do not ignite the fuel in the feeder canal and initiate the fire protection system

Adjusting the maximum feeder temperature

The sensor measures the temperature in the feeder. The threshold for the activation of the protection is set in the service menu of the controller. If the temperature of the feeder exceeds the set value, the regulator will start the feeder for a programmed fixed time of 3 minutes. **At the same time, the fan is switched off and the pumps are turned on. After the fuel is “pushed out”, the regulator turns of the feeder, and it will not turn it on even if the temperature is still high.**



DO NOT use oil, gasoline, paint thinners, or any other flammable substances to ignite fuel, as this may cause explosions.

3.2.3. CONTINUOUS OPERATION

After approximately 1 hour after setting the operating parameters, the device can be left unsupervised for the time between fuel loads. **Due to irregularities in fuel types, you must check the settings of the feed time, interval, and fan power after each load. Adjust them if needed.**

3.2.4. EMERGENCY OPERATION

In closed systems, emergency burning mode cannot be used without the safety measures described by the manufacturer (see chapter 2.5.2).

When igniting, do not fill the combustion chamber completely (wood - 50% fill, coal no more than 20% fill). The humidity of the fuel should be below 30%. Do not use coal dust.

Under no circumstance burn any PVC products: butter or margarine containers, toys, plastic construction materials; polyamides, such as textiles.

During the boiler's operation you should periodically monitor and refill fuel. To maintain a possibly stable temperature of supply water:

- use fuels with humidity below 30%
- if your fuel is more humid, dry it first or mix it with dry fuel
- when using fuels of different fragmentation, load it in turns
- if possible, avoid opening the load hatch when igniting
- Adjust the boilers output, and therefore the supply water temperature, by changing the setting of the throttle (or the adjustable damper on the ash drawer door), or by changing the diameter of the exhaust outlet on the flue. When using the boiler with a fan system, the air damper on the ash drawer door should be closed.



Note: avoid burning fine fuels, in which dusts concentration exceeds 5%. Pay attention when burning very dry sawdust (moisture content up to 10%), do not compact them tightly in the combustion chamber. Having charged the sawdust, leave free space in the rear part of the chamber to ensure air access. Failure to

meet these requirements may result in gases from combustion chamber backdrafting during sudden opening of the loading hatch. Opening the loading hatch may cause sudden growth of the air volume in the combustion chamber and explosive combustion of dusts

When operating a boiler with air supply system, do not open the charging flap during fan operation. Before supplementing the fuel, switch off the controller.

3.3 CLEANING AND MAINTENANCE

3.3.1. CLEANING THE EXCHANGER

Cleaning the exchanging surfaces should be done once a week and ash should be removed from the ash drawer and the back ash chamber when necessary. In the case of devices equipped in an ash removal system, removing ash consists only in emptying the ash container when it is full. In emergency combustion mode, the grate should be cleaned before each load of fuel. Sweeping the exchanging surfaces of the boiler should be done only after the flame in the boiler has died out. Use the enclosed cleaning kit.

In case of heavy contamination of the boiler, chemical agents removing boiler deposits may be used, but only such, which are allowed on the marked (i.e. with CE mark and instructions of use).

3.3.2. CLEANING THE HEAD

The head is equipped with a movable, self-cleaning grate which greatly extends the time between cleanings. In the heating season, the cleaning of the head consists of removing the sand and ash which got through the grate to the inside of the head. To clean the inside of the head, remove the cover of the head's cleaning hole. (1, Fig. 3.1) and sweep out the sand and ash from the space under the grate (2, Fig. 3.1). This process is described on the picture below. Perform the action once a week or when necessary. Do not allow the accumulated ash to touch the grate from underneath. In the case of fuels which are excessively contaminated or have a low ash sintering temperature (such as straw, sunflower seed husks, oat grain) it may be necessary to remove the residue from the furnace (3, Fig. 3.1) using the cleaning kit.

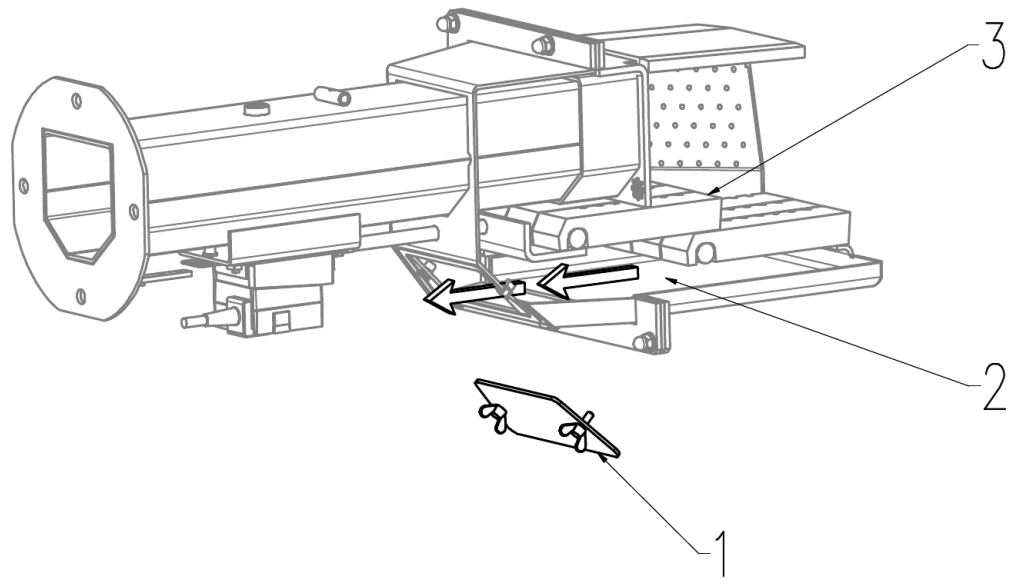

Fig. 3.1. Head cleaning schematic

1 - Cleaning hole cover, 2 - space under the grate, 3 - furnace

After the heating season's end, it is necessary to disconnect the head from the boiler and to inspect the grate. Remove deposit from cast-iron elements, check cast-iron surfaces (for cracks), clean air inlet holes. After cleaning, reinstall the head. If seals are damaged during maintenance work, replace them with new ones.

3.4. TURNING OFF THE DEVICE

3.4.1. PROGRAMMED SHUTDOWN

Boiler

After the fuel burns out, open all doors and maximally open the damper in the smoke conduit. Remove ash, clean the boiler. Do not drain the circulating water. Cool down time is equal to the ignition time.

Feeder

If the fuel in the container is supplemented on ongoing basis, the feeder will work continuously. In order to stop the device, e.g. to prepare it for ash removal, place the power supply switch in „0“ (zero) position.

3.4.2. EMERGENCY SHUTDOWN

Boiler (applies to the emergency operation mode after feeder disconnection)

In case of emergency situations, such as exceeding 100⁰ C temperature, the installation's elements break, loss of water charge, control & automatic equipment or protection equipment failure or sudden pressure increase, it is necessary to:

- remove fuel from the grate and move it out of the boiler room
- decrease the circulating water temperature by adding cold water to the water charge, like during filling
- maximally open the smoke conduit throttle (if installed)

In the case of boilers operating in closed system, an emergency condition may be any condition resulting from power outage (pumps stop) or from leaving doors of the boiler open. The central-heating installation shall be protected with a safety valve set to 2 bars, additionally the manufacturer shall protect the boiler with a safety valve, factory pre-set to 2.5 bar, however, in case of an emergency condition, such protection is insufficient. The boiler must be additionally protected with a thermal protection valve, which will remove the hot water from the boiler in case of an emergency condition, while at the same time supplementing the resulting shortage of water in the boiler with cold water from the water network installation in order to cool down the boiler and to reduce the pressure (section 2.6).

Keep in mind that emergency conditions are likely to occur in summer, when only household hot water is heated in the boiler. Anticipating such conditions, it is worth to consider installing a heat accumulator capable of taking over the heating power surplus unavoidable in such circumstances.



DO NOT pour water over ambers.

Feeder

Set the regulator to IGNITION Set feeding to OFF and the fan to ON. The fan will cause the fuel remaining on the grate to burn out and then it will start cooling down the head. Open the throttle in the boiler. After the fuel burned out, you can open the boiler's doors in order to cool it down. When the temperature begins to fall, turn off the device.

4. TROUBLESHOOTING, SAFE OPERATION CONDITIONS

The main precondition of boiler safe operation is construction of its installation and protections according to Polish standards.

In order to maintain safe operating conditions of the boiler, it is necessary to follow the principles listed below:

- wear protective gloves and goggles
- do not block charging flaps and ash drawer doors
- use portable 24V lamps
- maintain order and cleanliness in the boiler room
- maintain good technical condition of the boiler and its related installation
- during the winter season ensure that the heating process is continuous



If water freezing in the installation is suspected, check whether safety piping is not blocked. The water added to the water charge in the installation shall return through the overflow pipe from the pressure vessel. If safety piping is blocked, the boiler must not be ignited, and if it has been operating, proceed as in boiler emergency shutdown procedure (see p. 3.6.).

4.1. INSTALLATION OF THE FUEL CONTAINER IN A NON-HEATED ROOM

Installation of the fuel container in unheated rooms does not constitute a problem to the container operation as such. However, condensation resulting from changes of atmospheric conditions, combined with the heat conducted by the screw shaft may cause the device to freeze when the outdoor temperature drops.

If the water container is located in the same premises, it will be necessary to use an anti-freeze agent.



Note: Gas pressure decreases with temperatures drops. Gas cylinders of the container flap will behave differently under such conditions.

4.3. TROUBLESHOOTING

No.	Fault	Cause	Solution
1	Flame backdrafting to the fuel container	<ul style="list-style-type: none"> - no fuel in the container or fuel level too low, - fuel clogging, - container cover not fully closed 	<ul style="list-style-type: none"> - refill the fuel container, - mix the fuel - check cover tightness
		<ul style="list-style-type: none"> - blocked screw shaft - power outage for a longer period - no water in the container 	<ul style="list-style-type: none"> - determine the cause and remove the failure - empty the container of the fuel and flood the screw shaft line with water - refill the water tank
		<ul style="list-style-type: none"> - insufficient chimney draught 	<ul style="list-style-type: none"> - use an exhaust fan, improve the draught
2	Fuel clogging in the container	<ul style="list-style-type: none"> - using sawdust with dusts content of more than 5%, - too high moisture content in fuel (above 40%), the fuel freezes to container walls during the winter season 	<ul style="list-style-type: none"> - change the fuel - add a portion of dry fuel and mix it thoroughly
3	Smoke in the container	<ul style="list-style-type: none"> - head contamination - blocked chimney - boiler cover and doors not fully closed 	<ul style="list-style-type: none"> - clean ash in the head - clean the chimney - close covers and doors in the boiler
4	Screw shaft does not rotate	<ul style="list-style-type: none"> - power outage - blocked screw shaft - damaged screw shaft and agitator 	<ul style="list-style-type: none"> - start left rotation, then restart (see par. 4.3.1.) - replace the screw shaft, replace the agitator
5	Loud operation of the feeder unit	<ul style="list-style-type: none"> - damaged electric motor bearing, - gear-motor oil leak, - damaged agitator bearing, - foreign body (e.g. metal) in the screw shaft pipe 	<ul style="list-style-type: none"> - replace the bearing - seal any leaks, add oil, - replace the bearing - remove the screw shaft, remove the foreign body
6	Quick deposit build-up	<ul style="list-style-type: none"> - excessively contaminated fuel 	<ul style="list-style-type: none"> - do not burn coal, coke, fine coal, plastics and rags, use fuels according to the instructions, - remove deposit

7	Boiler cannot reach the pre-set temperature	<ul style="list-style-type: none"> - contaminated fan - too much ash in the (cast-iron) head, blocked ventilation openings in the head - too high moisture content of fuel, - incorrect controller settings 	<ul style="list-style-type: none"> - clean fan blades - remove ashes from the head through the washout opening - charge correct fuel - set correct feed and pause times
8	Fire water tank emptying	<ul style="list-style-type: none"> - flame backdrafting to the fuel container 	<ul style="list-style-type: none"> - undo the connector, insert beeswax plug. If the container has been emptied when using sawdust, the fuel in the pipe must be cleaned as soon as possible, as sawdust expands and may permanently block the machine – immediately force feeding of the combustion chamber with fresh fuel.

4.3.1. PROCEDURE IN CASE OF SCREW SHAFT JAMMING

The device has stopped: - Make sure that the device is switched off. If the boiler is set to maintain the flame, the fan and the screw shaft may not activate for longer periods.

The device has stopped (and has cooled down): - Boiler may have overheated causing the device to shut down. Restart the controller.

The device has stopped (display message „BLOKADA PODAJNIKA” - /feeder jammed/):

- It is likely that a stone, a root, etc., got into the system through the screw shaft. Re-engage the thermal protections switch.

If the feeding worm shaft does not rotate in the forced supply mode, the follow these steps:

- Open the revision slot and perform an inspection,
- Sometimes it may be necessary to reverse the screw shaft's rotation. To do this, having previously disconnected the power supply, switch any 2 phases and switch the controller and feeding briefly on.
- Remove the stone, root etc. which caused the failure through the inspection hole.
- Make sure that the screw shaft operates correctly and tightly close the inspection hole.

5. SPARE PARTS

5.1. MAIN SPARE PARTS LIST

No.	Part name	Part number
1.	Electric motor with gear-motor	3
2.	Agitator	8
3.	Screw shaft	4
4.	Cast iron head GZZ20	1

The part numbers refer to Fig. 1.5

5.2. LIST OF WEARABLE PARTS*

No.	Part name	Part number
1.	Door seals	Z1
2.	Ash container (100kW+ versions)	Z2
3.	Air supply control arm	Z3
6.	Cast iron head grate	Z5
7.	"Fireman" safety valve	Z6

***NOTE: The aforementioned parts are not subject to warranty replacement. If their replacement is needed, they are available for purchase from Moderator Sp. z o.o. service department.**

6. DISPOSAL

Assuming correct operation, the boiler should operate without problems for about 15 years. After that time, its further operation may be economically unjustified. The boiler is made of materials which are fully recyclable. It is recommended to provide it for disposal to a specialized machine disassembly and disposal company.

In case of the feeder, the fault-free operation time of the head (provided it is maintained, operated and serviced properly) shall reach several years (7 to 9). After that time, it may be necessary to replace cast-iron grate inserts. If the repair is no longer economically reasonable, the best way will be to dispose the head. In case of the head, the simplest way of disposing it is to send it to a metal specialized scrap metal collection plant.